

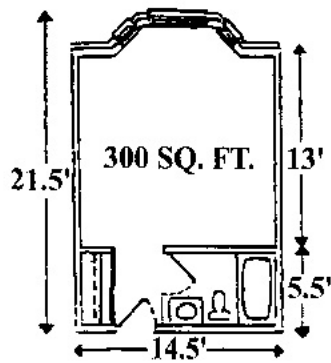

99 WALFORD ROAD, SUDBURY, ONTARIO P3E 6K3

## Floor Plans

\*Drawings are not to scale & square footage approximate



STANDARD PRIVATE  
\*300 SQUARE FEET  
STUDIO

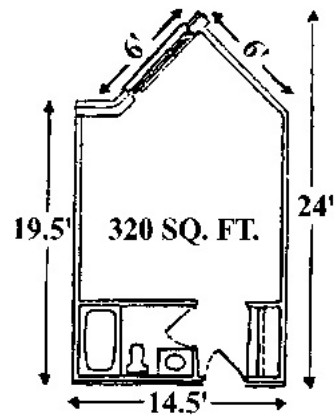

LARGE PRIVATE  
\*320 SQUARE FEET  
STUDIO

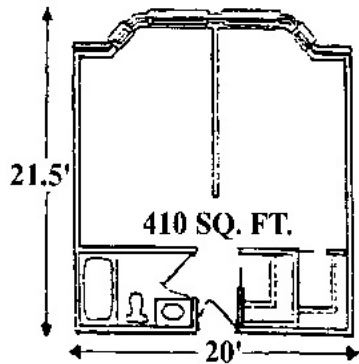

DELUXE PRIVATE  
\*410 SQUARE FEET  
1BEDROOM SUITE

DELUXE SPECIAL  
\*420 SQUARE FEET  
1 BEDROOM

---

SUPERIOR PRIVATE  
\*450 SQUARE FEET  
1 BEDROOM SUITE

---

MASTER SUITE  
\*600 SQUARE FEET  
1 BEDROOM SUITE WITH KITCHENETTE

# The Walford Services and Amenities

---

## **DISTINGUISHED SERVICES**

- ◆ Dining Service with Delicious and Nutritional Meals in Our Gracious Dining Room
- ◆ Weekly Personal Laundry
- ◆ Weekly Light Housekeeping
- ◆ Monthly Social, Devotional and Recreation Programs
- ◆ Scheduled Transportation to Shopping and Special Outings
- ◆ Security of Professional Support Staff Around the Clock
- ◆ Medication Management
- ◆ House Physician

## **GREAT ACCOMMODATIONS**

- ◆ Choice of Standard, Large or Deluxe
- ◆ Spacious Bathrooms with Safety Bars
- ◆ Generous Closet
- ◆ Individual Heat Control
- ◆ Wall to Wall Broadloom
- ◆ In-house Phone and Staff Call System
- ◆ Staff Alert System
- ◆ Jacks for Cable Hook-up
- ◆ Single Storey for Safety and Convenience

## **EXCEPTIONAL SURROUNDINGS**

- ◆ Well Appointed Dining Room
- ◆ Lounges for Snacks, Beverages and Conversation - Open 24 Hours
- ◆ Intimate Common Areas
- ◆ Library
- ◆ Comfortable Furnishings
- ◆ Walk-in Shower Room
- ◆ On-site Hair Salon and Barber Shop
- ◆ Beautiful Landscaped Walking Paths and Patios
- ◆ Garden Club
- ◆ Parking and Plug-in (Upon Availability)

## **ADDITIONAL COSTS MAY INCLUDE**

- ◆ Monthly Phone and Long Distance Charges (As per the Landlord's Choice of Carriers)
- ◆ Transportation
- ◆ Guest Meals
- ◆ Special Dietary Needs
- ◆ Individual Care Services Such As: Hair Care and Foot Care

99 Walford Road  
Sudbury, Ontario P3E 6K3

**Telephone: (705) 523-2686**